

# Pelmet

## Assembly Instructions

- Take great care handling and lifting parcels
- Open parcels with care to avoid damage
- Check the label to see the contents of each parcel
- If you have ordered several items, keep it simple: only unpack one item at a time
- Use the the Parts Diagram sheet to identify and distinguish between parts
- Any questions: call us on **01227 833333**, or email **sales@jali.co.uk**

### YOU WILL NEED

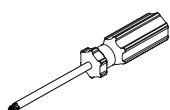

5mm Pozi  
Screwdriver



Wood  
Glue

### EXTRA

- To assemble the unit, you may require clamps to hold it in place while the glue dries. Alternatively, you may prefer to pilot drill and screw it together, or use panel pins. Use filler to hide any holes/screw heads
- To install, you may require a masonry drill, a spirit level and a helping hand

### FIXINGS INCLUDED

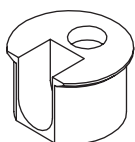

White Cam

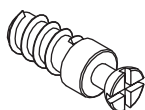

Cam Bolt

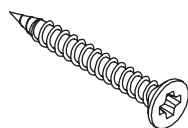

30mm CSK  
Screw

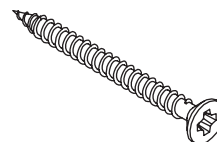

40mm CSK  
Screw

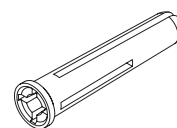

Wall Plug

### HOW DO CAM & BOLTS WORK?

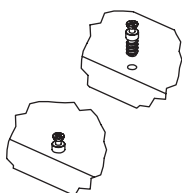

1. Screw in the Cam Bolt, up to the shoulder, into the 5mm hole in one part.

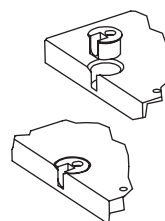

2. Push the Cam, facing outwards, into the corresponding hole on the other part.

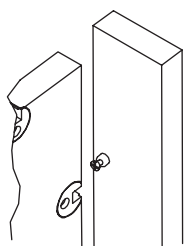

3. Push the two parts together, so that the Cam Bolts disappear into the middle of the Cams.

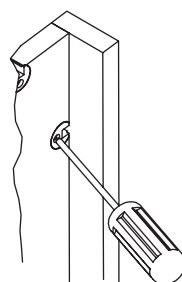

4. Insert a 5mm Pozi screwdriver – tilt back at a slight angle – and rotate CW to lock the Cam.

## SEE HOW IT COMES TOGETHER

---

1. Start by identifying the parts. Your design may be different to this example, but don't worry; the approach will be very similar. You'll either have a single pelmet or a kit which will make up a pelmet box. For very long units, the Top Board and Front may come in multiple pieces. Some styles also come with a decorative Centrepiece.

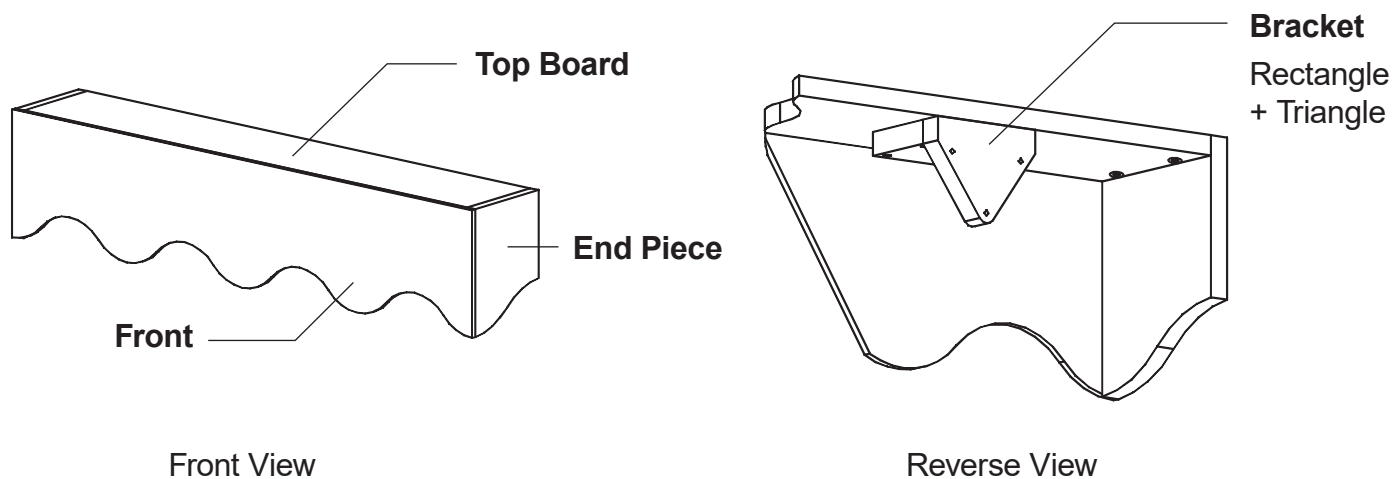

## ASSEMBLY

---

2. Push Nickel Cams into the holes in the Top Board, facing outwards. Screw Cam Bolts into the 5mm holes in the End Pieces. Fix the End Pieces to either end of the Top Board by locking the White Cams.

3. Now, fix the Front and any Centrepiece to this assembly. We would normally recommend using wood glue, and clamping the unit together while it dries. However, you may prefer to use screws (drilling pilot holes first) or panel pins, and a small amount of wood filler to cover any holes or screw heads.

4. Push White Cams into the holes in the Bracket Rectangles, facing outwards. Screw Cam Bolts into the 5mm hole in the Bracket Triangles. Each pair locks together to form a quick release Bracket. Fix the Brackets to the underside of the top board with 30mm CSK Screws through the Bracket Rectangle. The Bracket Triangles should be level with the back of the Top Board so they will fit against the wall. We recommend you place one bracket about a quarter of the way in from each end, but you may need to adjust this if you have obstructions on the wall. Bear in mind that if space is limited, you may have to use other ways of fixing – like mirror plates, for example.

## FITTING

---

5. Hold the assembled unit against the wall where you'd like it to be. You'll probably need someone to help at this stage, particularly if it's a long pelmet. Make sure it's level, and mark the location of the Bracket Triangle holes on the wall. Now you can put the unit down, and unlock the Bracket Triangles.

6. To fix the Bracket Triangles to the wall in the marked positions, we've supplied Wall Plugs and 40mm CSK Screws. These are suitable for fixing into normal masonry, however other kinds of wall may require need different fixings. Use a 5.5mm masonry drill to make the initial holes, push in the Wall Plugs, then screw the 40mm CSK Screw through the Bracket Triangle holes to fix them to the wall.

7. Carefully slide the box unit back onto the Bracket Triangles, and tighten the cams to hold the unit in place.

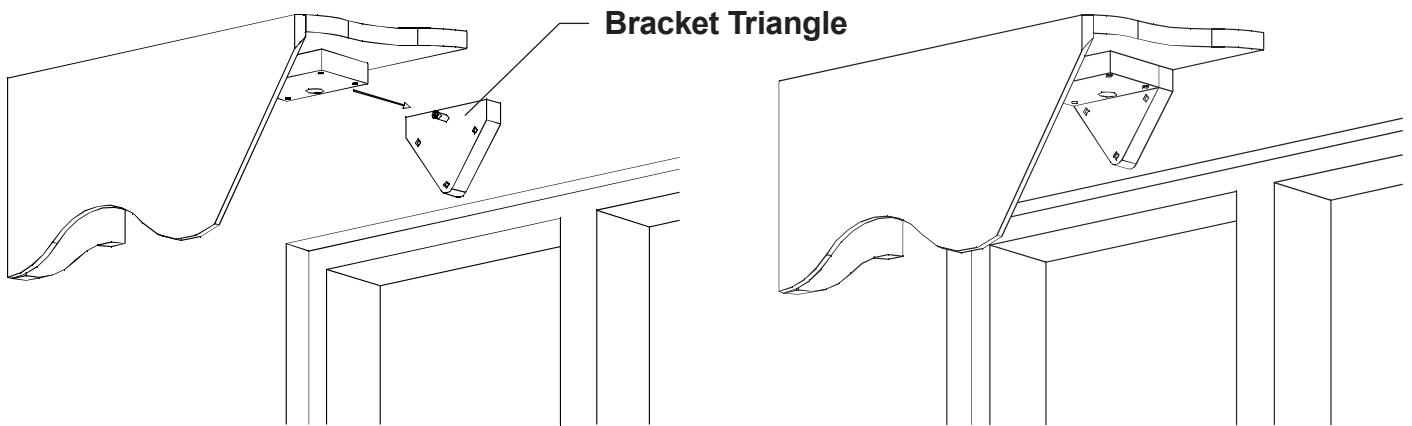

**AND YOU'RE DONE!**

#jali #pelmet #makeityours