

Cupboard – Multi

Assembly Instructions

- Take great care handling and lifting parcels
- Open parcels with care to avoid damage
- Check the label to see the contents of each parcel
- If you have ordered several items, keep it simple: only unpack one item at a time
- Use the the Parts Diagram sheet to identify and distinguish between parts
- Any questions: call us on **01227 833333**, or email **sales@jali.co.uk**

YOU WILL NEED

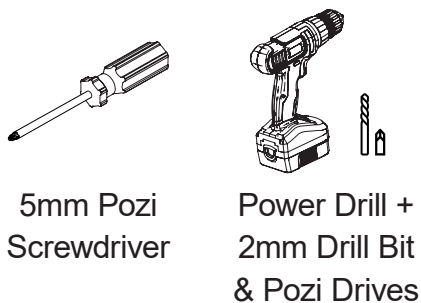

EXTRA

- You must fix your product safely in place. Depending on your situation, you may choose to use a drill, suitable screws and wall plugs
- You may wish to use Wood Glue to fix skirting in place
- To ensure a perfect fit with your room skirting board, you may use a saw to scribe the relevant parts during assembly

FIXINGS INCLUDED

Plus Door Handles with Bolts as required

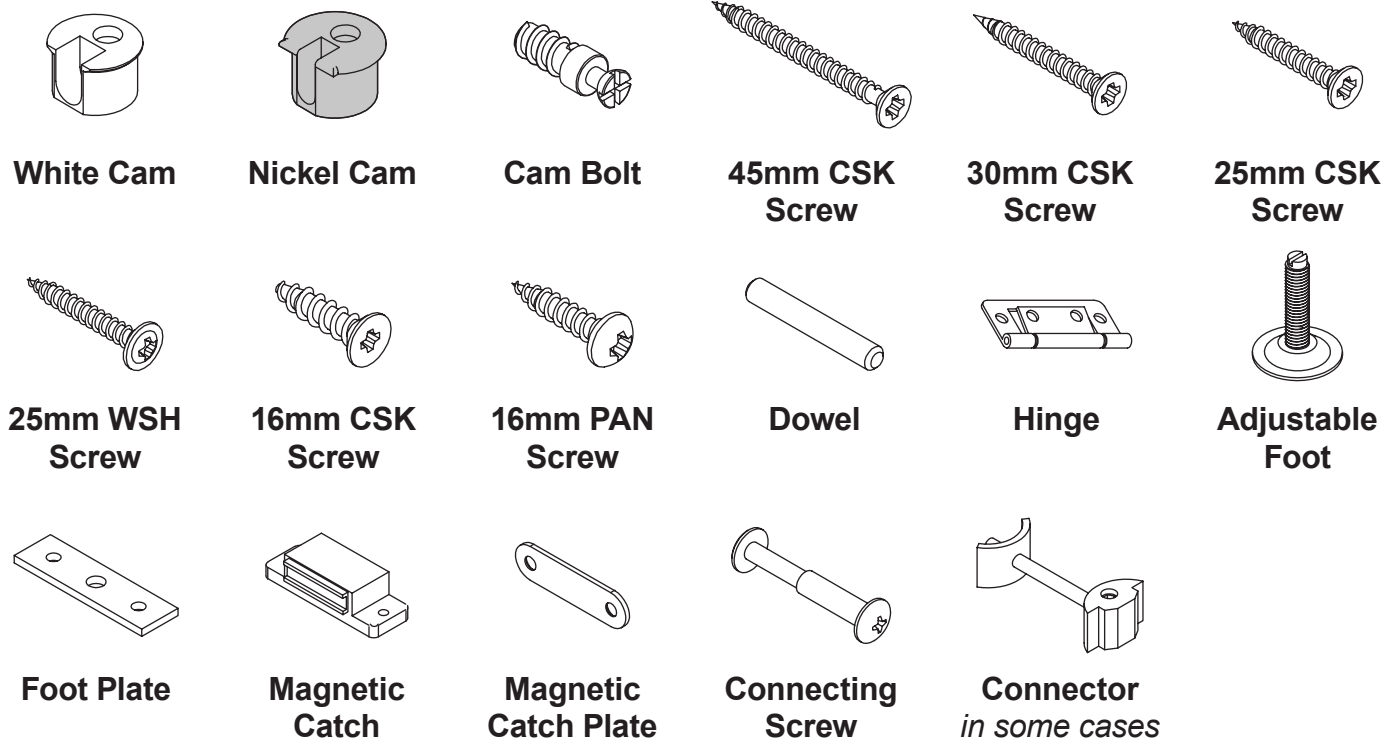

SEE HOW IT COMES TOGETHER

This unit contains two or more sections, or 'boxes'. The boxes can be built up independently and connected together, before the Top, Uprights and Skirting are attached. Each Box Top, Box Base, Box Back and Sides are engraved with the relevant box number. Your design may be different to this example, but don't worry; it will become clearer as we work through.

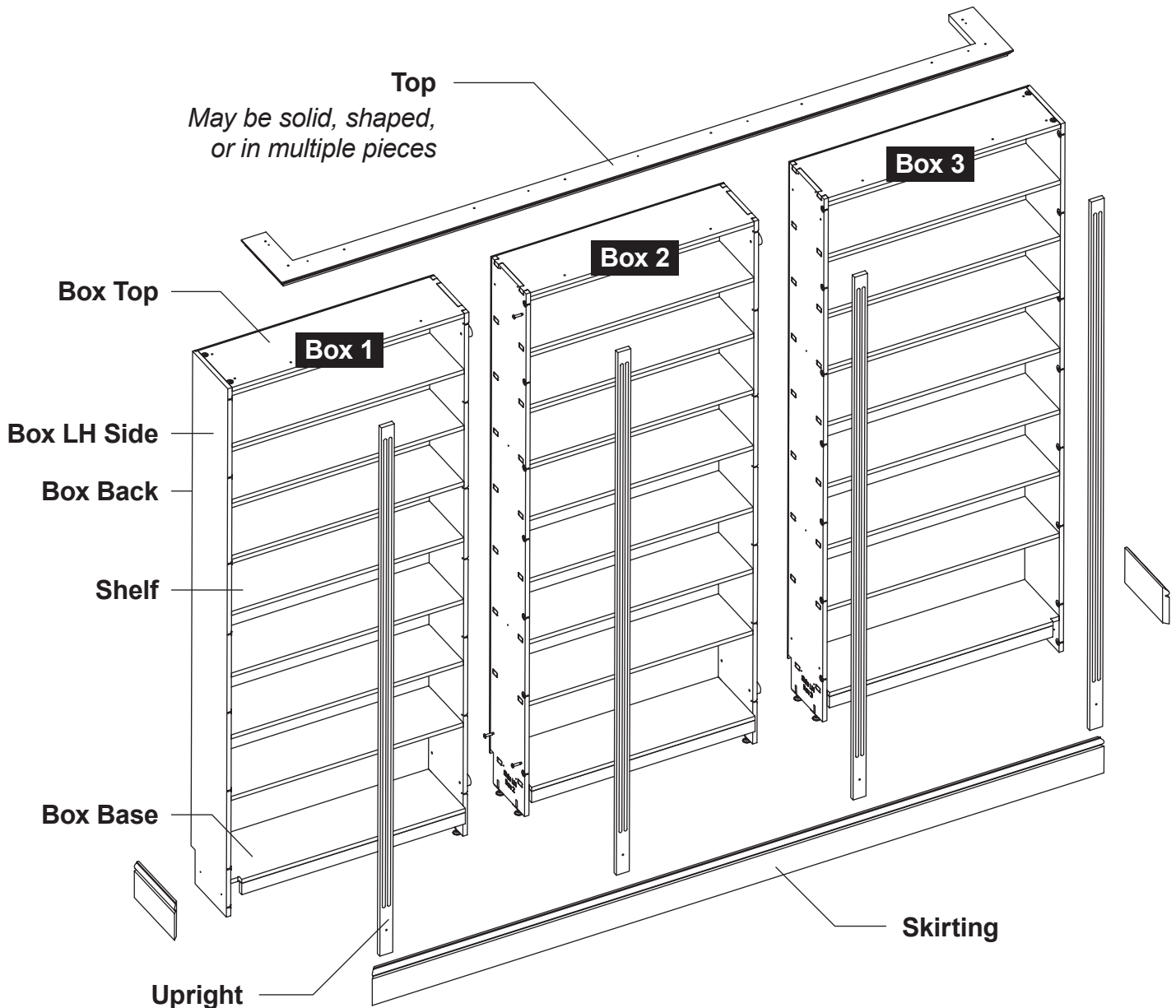

Shown without Doors

The **Outer** Box Sides are the ones at each end of the whole unit, e.g. *Box 1 LH Side & Box 3 RH Side*. The **Inner** Box RH Sides have a spacer attached where the boxes will be connected together.

Depending on your design, each box may have its own configuration of Shelves and/or Dividers. Refer to the Parts Diagram to confirm this arrangement.

PLACE FIXINGS

1. Identify the two Box Sides that will be at each end of the finished unit. Note these parts have blind tenon recesses and a rebate along the rear edge. For each, place the Nickel Cams in all the available holes, facing outwards. Using a screwdriver, or power tool on a low setting, screw the Cam Bolts into the available 5mm holes.

(Outer) Box Side

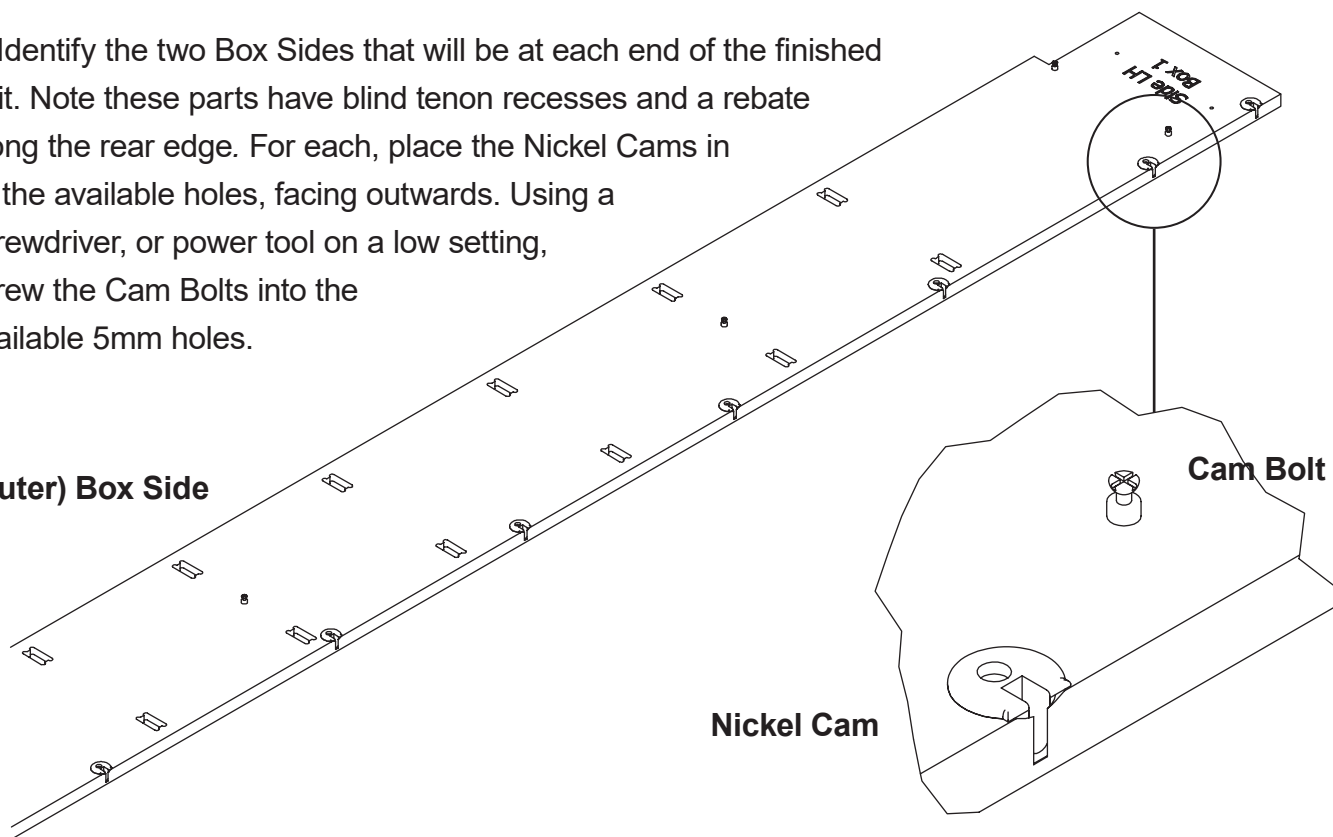

2. All the remaining Box Sides use White Cams instead, as they will be hidden. Place the White Cams in all the available holes, facing outwards. Attach the Adjustable Feet using the Foot Plate and 16mm PAN Screws for each assembly. However, you should pilot drill these first to avoid splitting the wood. The Adjustable Foot should be set to about 25mm.

White Cam

(Inner) Box Side

Front Edge

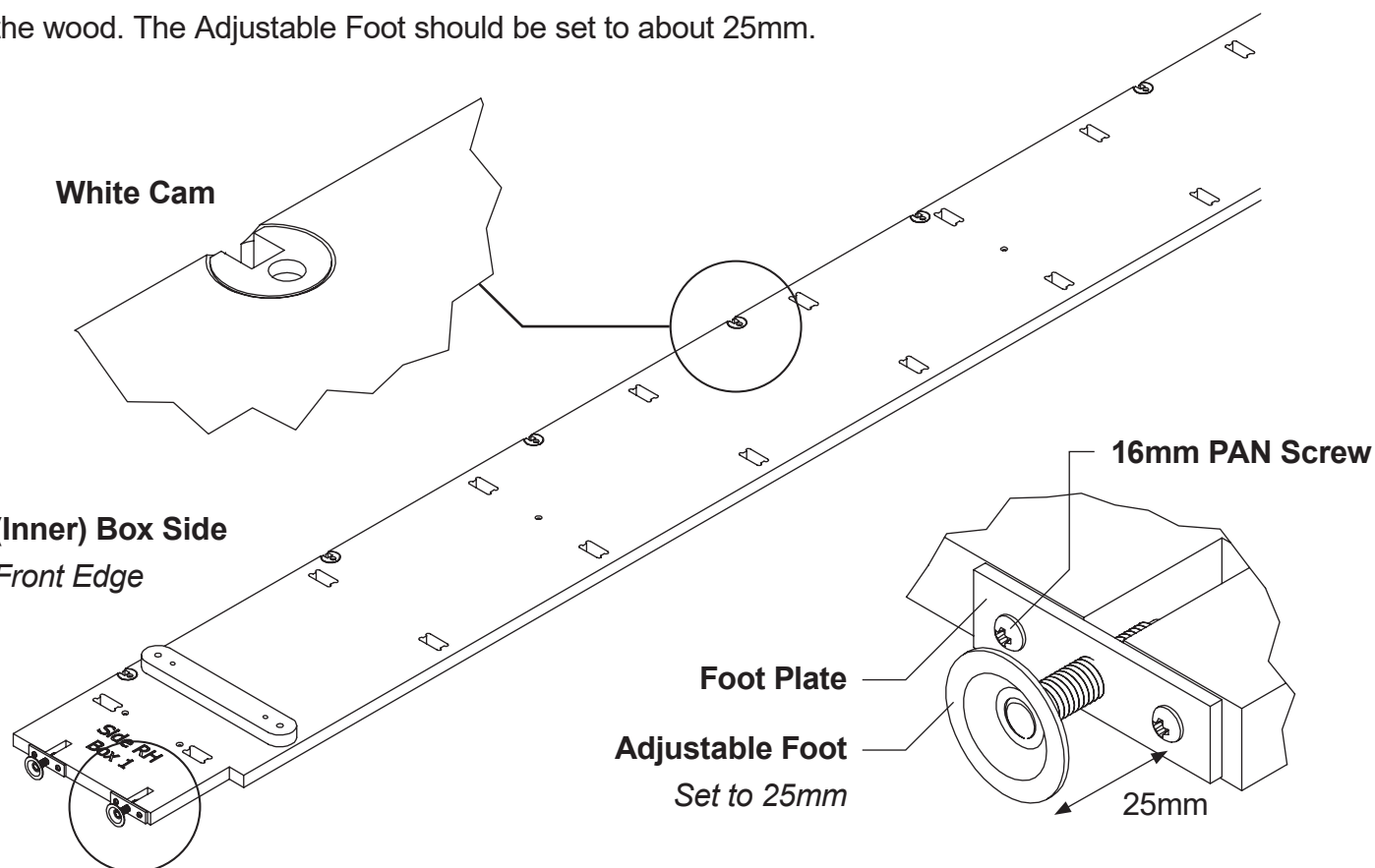

HOW DO CAM & BOLTS WORK?

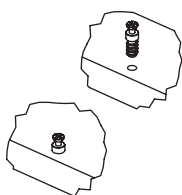

1. Screw in the Cam Bolt, up to the shoulder, into the 5mm hole in one part.

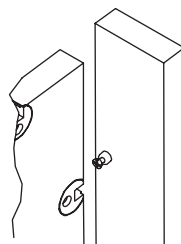

3. Push the two parts together, so that the Cam Bolts disappear into the middle of the Cams.

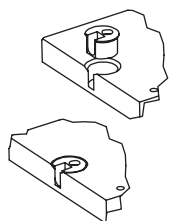

2. Push the Cam, facing outwards, into the corresponding hole on the other part.

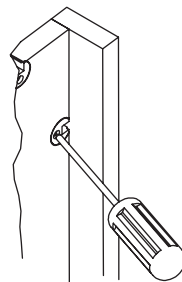

4. Insert a 5mm Pozi screwdriver – tilt back at a slight angle – and rotate CW to lock the Cam.

3. This example does not include any Dividers. However, if your design does, look for 5mm 'through' holes. Each hole requires a Cam Bolt on each side. Screw in all Cam Bolts required on one side of the Divider, then turn the Divider over, and screw in Cam Bolts, in the same holes, on the opposite side.

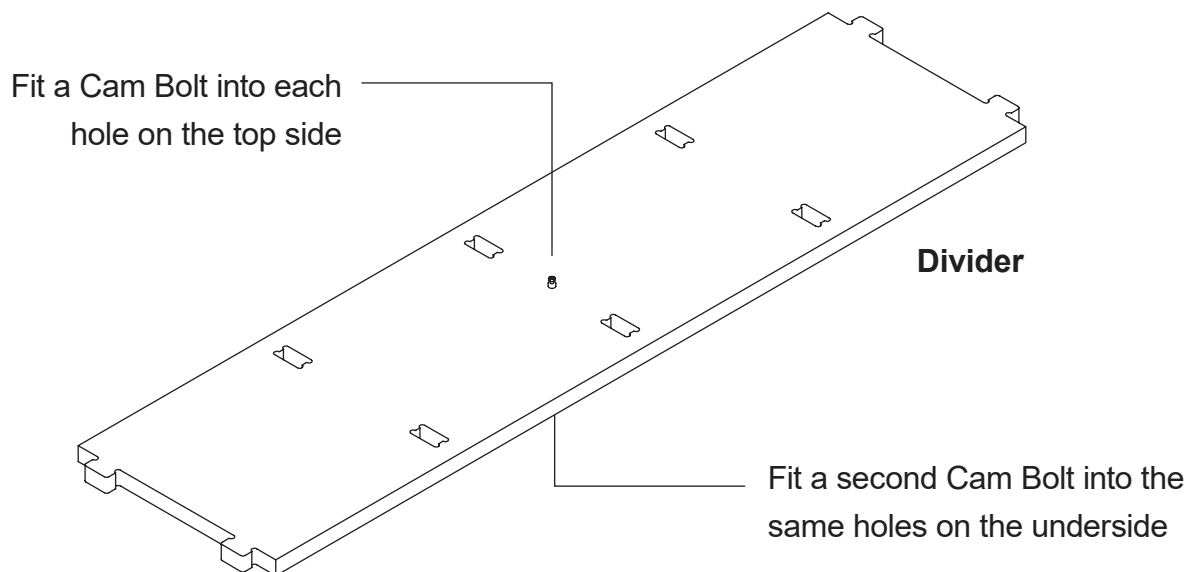

4. On taller units, one or more of the outer Shelves (in the outer boxes) may have a cam hole. Place Nickel Cams in these.

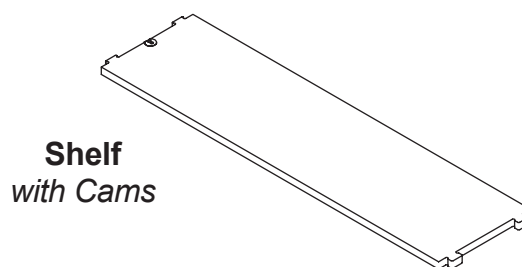
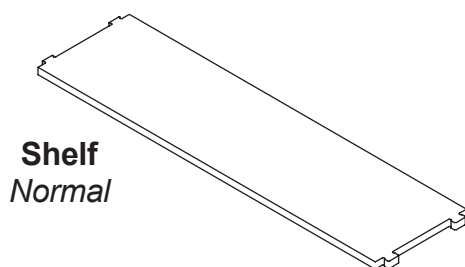

5. For all the Uprights, fit Cam Bolts to all 5mm holes. There is also a 6mm hole - leave this for now.

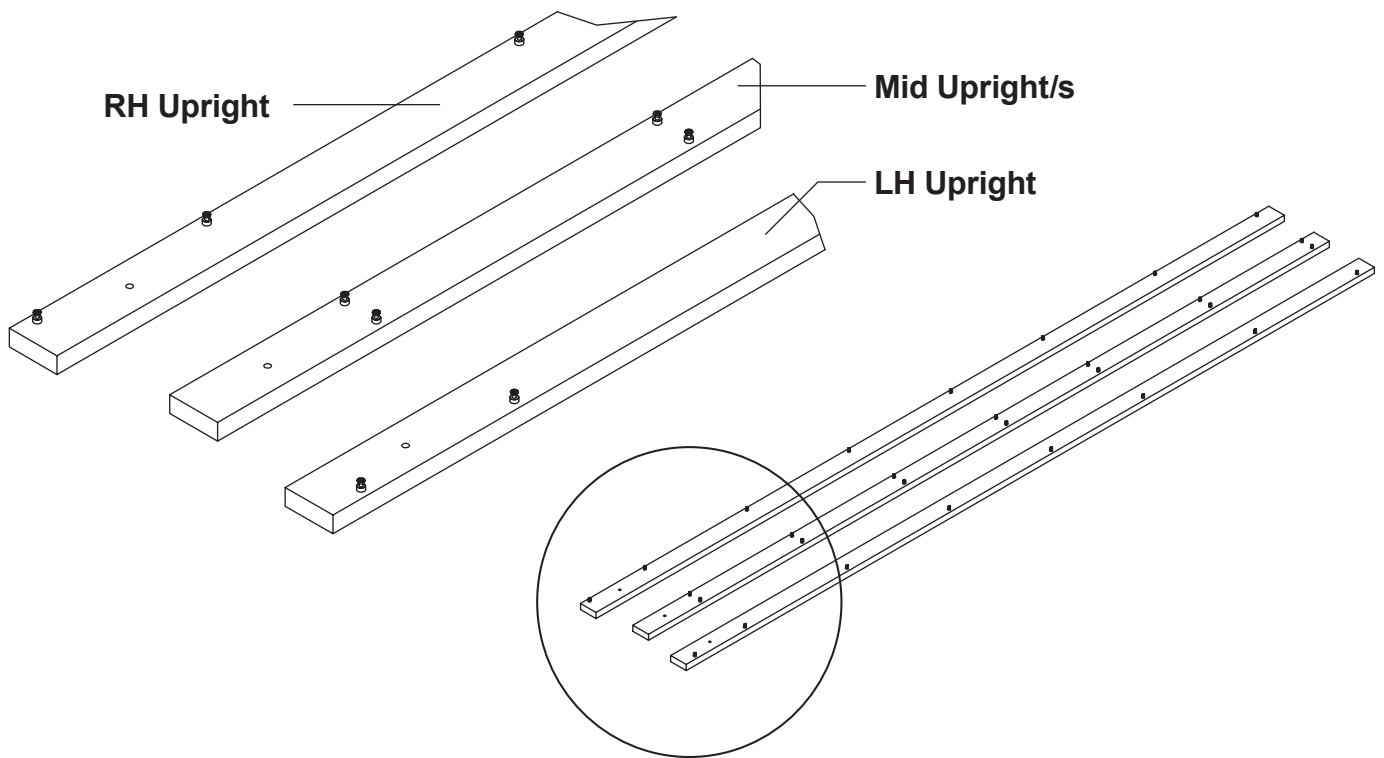

6. Place White Cams in the Box Base, Box Top and Valance cam holes. Depending on your design, the Valance strip could be taller than this example. Screw Cam Bolts into the 5mm holes along the Box Base front edge.

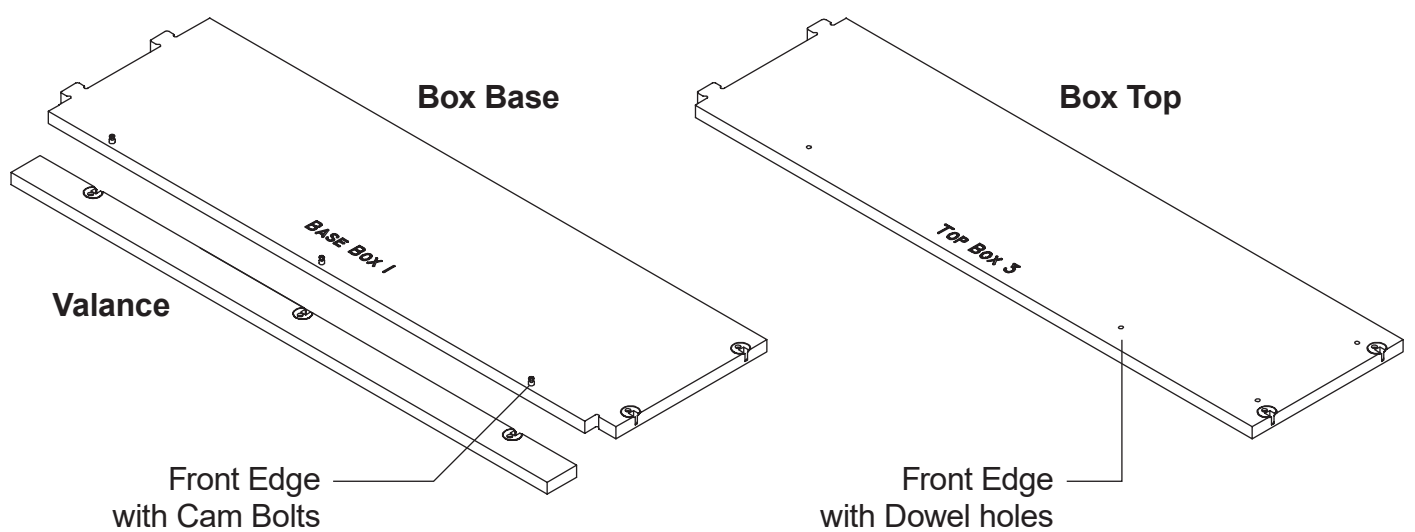

BOX ASSEMBLY

7. Align the Valance White Cams with the Box Base Cam Bolts, then lock each cam securely in place. See Page 4 for help with cams.

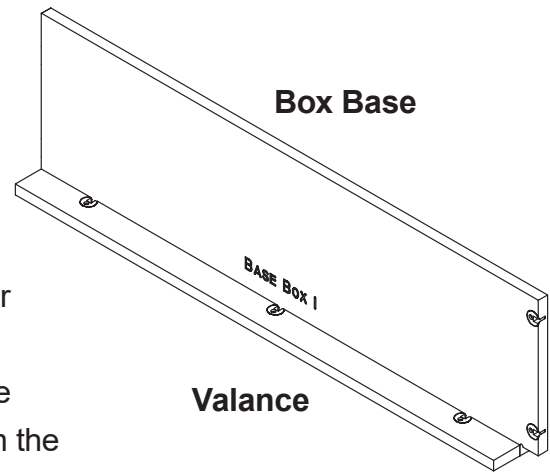

8. The following instructions will cover the assembly process for a single box. Simply repeat this process for each box in your design, referring to the engraved box numbers on each of the Box Sides, Box Top, Box Base and Box Back, as well as the Parts Diagram to confirm the configuration of Shelves and/or Dividers for each box.

Note about Dividers

If the box has **more than one Divider**, start by placing all the necessary shelves between the Dividers. Wherever (if) the Divider features a central Cam Bolt, place one of the Shelves with cams. After locating the other normal Shelves, lock these Shelf cams into place to hold the structure together.

If the box has **just one Divider**, the Box Top and Box Base can now be attached either end of the Divider, before fixing with 45mm CSK Screws.

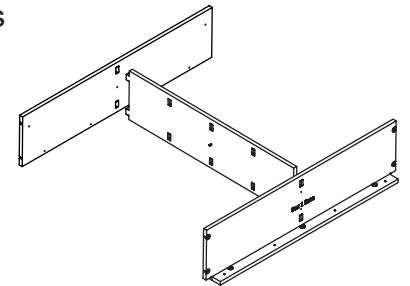

Note that the following example has no Dividers.

With the front edges toward the floor, fit the Box Top to the RH Side and secure with 45mm CSK Screws. Then proceed to add all the Shelves. Wherever (if) the Box Sides feature central Cam Bolts, place one of the Shelves with cams, with the cam facing towards the Box Base.

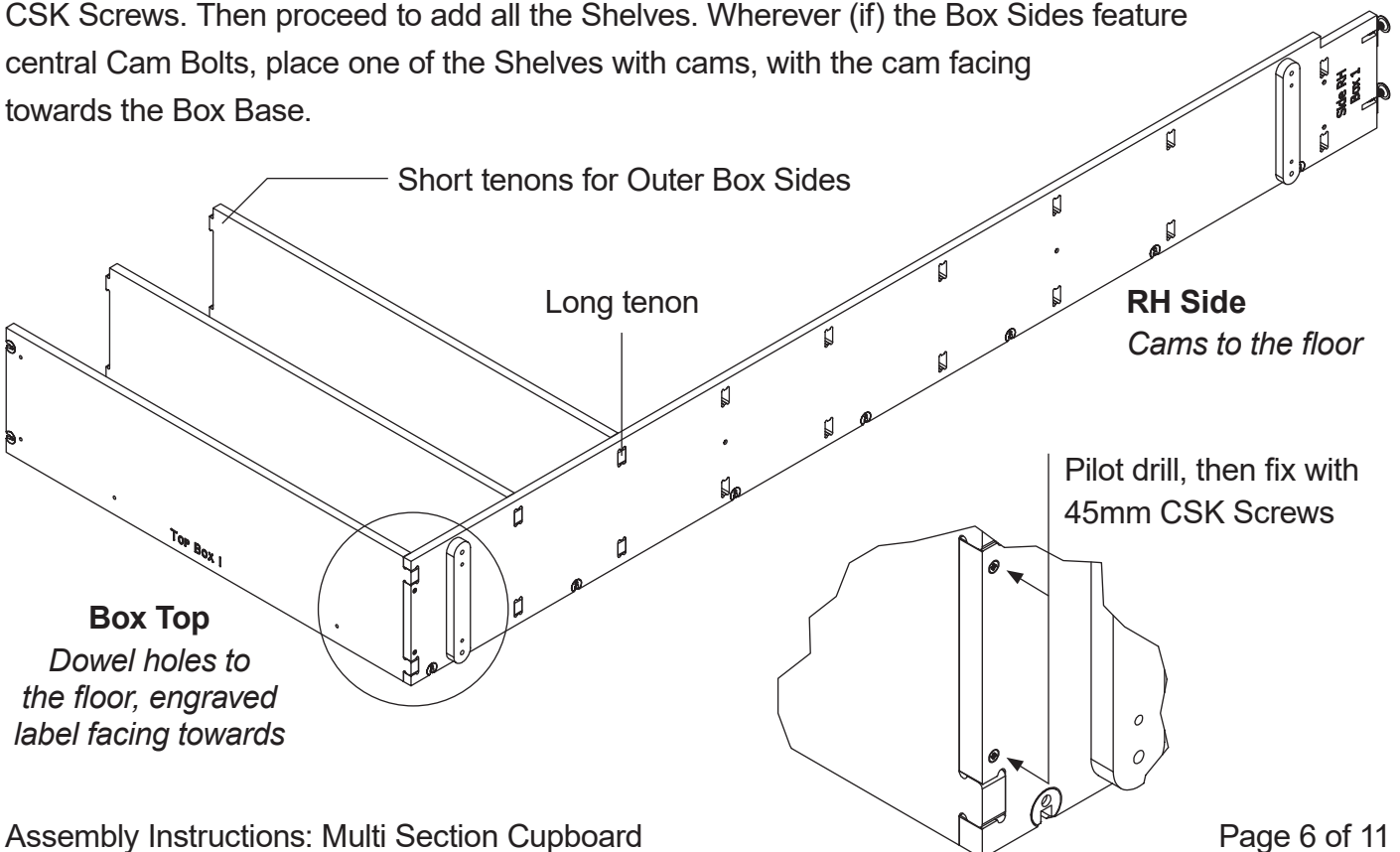

9. Once the Shelves and the Box Base assembly are placed in the RH Side, the LH Side can be located. Ensure that the Shelves with cams align with the Cam Bolts in the LH Side, and lock these into place. Lock the cams in the Box Top and Box Base.

Fit 45mm CSK Screws through the 4mm holes (in the RH Side) into the Box Top, Box Base and Shelves with cams

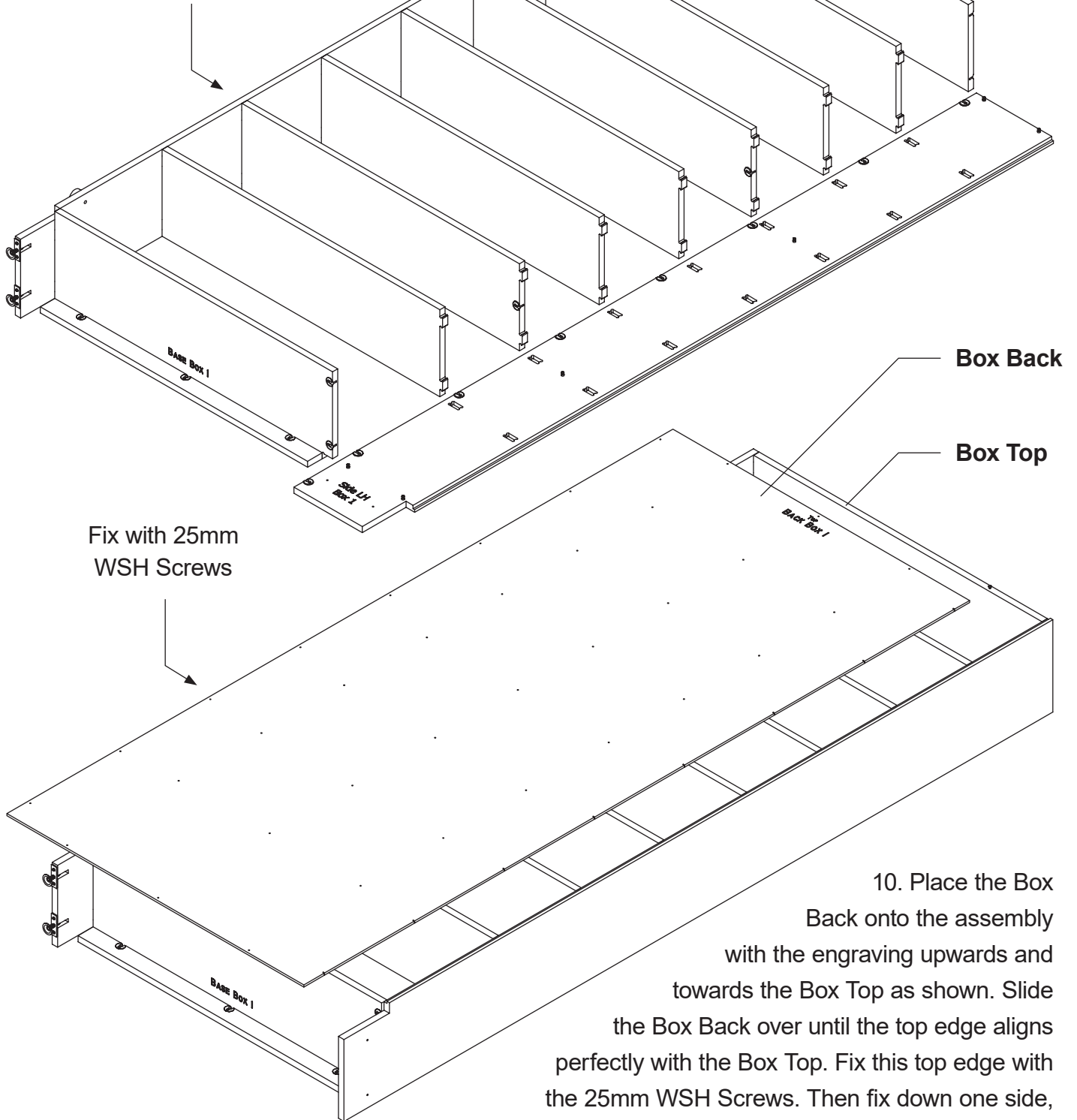

10. Place the Box Back onto the assembly with the engraving upwards and towards the Box Top as shown. Slide the Box Back over until the top edge aligns perfectly with the Box Top. Fix this top edge with the 25mm WSH Screws. Then fix down one side, accurately realigning the edge to the Box Side as you go.

This should force the box square. Once all sides are fixed in place, continue to screw through the remaining 3mm holes with 25mm WSH Screws to help secure the Shelves.

NOW ASSEMBLE ALL THE OTHER BOXES

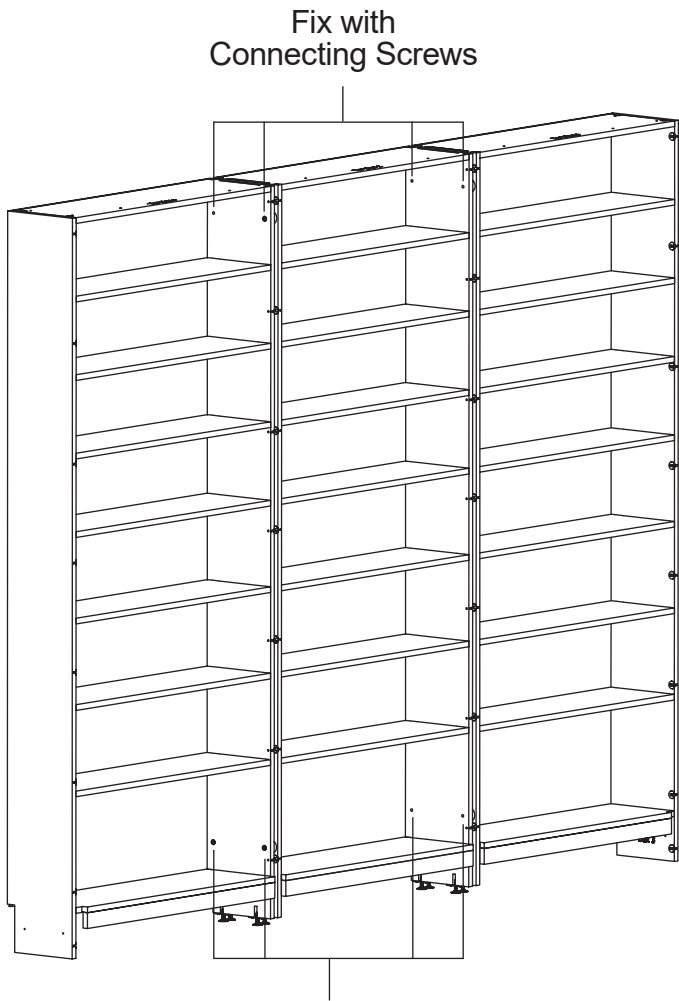

11. Carefully stand the boxes up and position them adjacent to each other in the correct order. If they are too large to do safely, you'll need to enlist some help. Ensure that they will not fall.

Adjust the feet height as necessary to bring the boxes in line with each other.

Connect the boxes together with two pairs of Connecting Screws, at the top and bottom of each box. Check that the screws engage properly before placing the larger (female) part through the RH Side, and then engage the screw from the LH Side. You may need two large pozi/flathead screwdrivers to fully engage the Connecting Screws.

Fix with Connecting Screws

12. Fit the Uprights to the Sides by aligning the cams and locking them into place.

Ensure all the cams are fully open before placing the Uprights.

To lock the Mid Upright cams, use a pozi screwdriver via the access holes on the Inner Box Sides

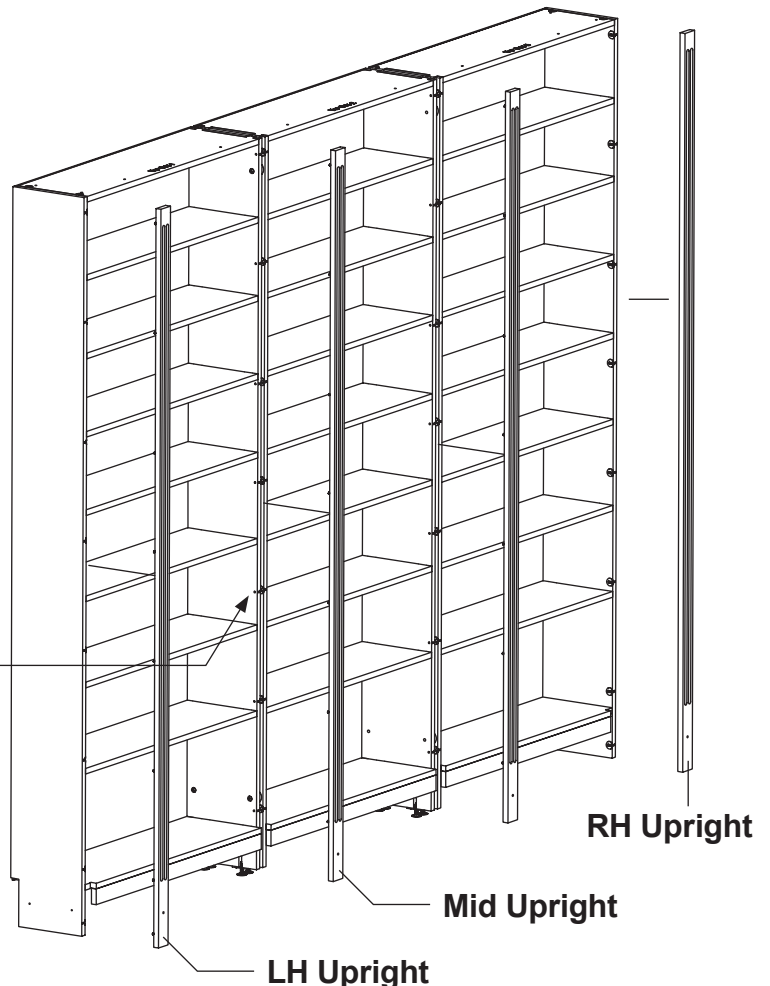

13. Fit Dowels into the Front Skirt holes, and push home the Front Skirt into the holes on the Uprights and Valances. This can be glued into place, or left as is. Depending on your design, you may have LH and/or RH Skirts. If you wish, you can scribe these Skirts to match your room skirting. When placing the LH & RH Skirts, ensure that the mitre matches neatly with the Front Skirt. They can be either glued in place, or screwed from the inside using 30mm CSK Screws.

14. Depending on your design, you may have one of a variety of different Top styles. The most common is simply a solid Top board.

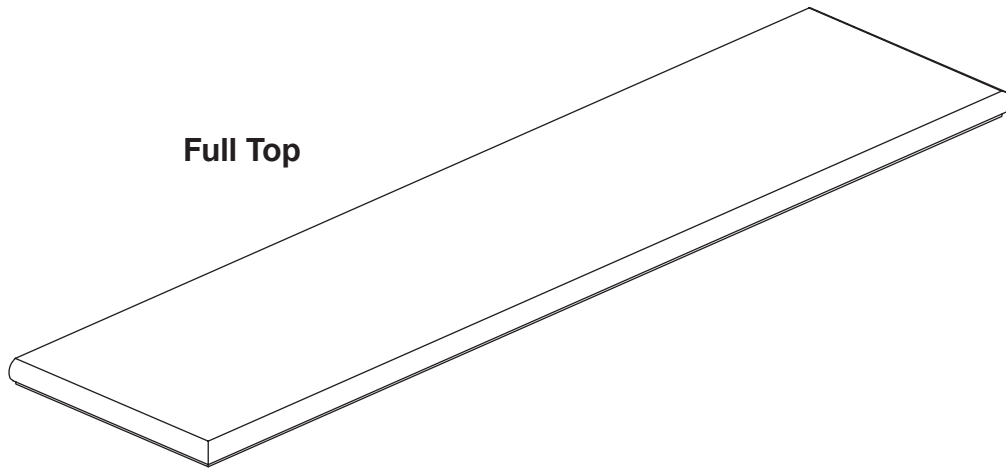

Alternatively, you may simply have a Top 'lip'. This can be located using Dowels, and glued or screwed from above. This may be supplied as one single component or several parts which join together with a Connector (using the hex key provided) once in place.

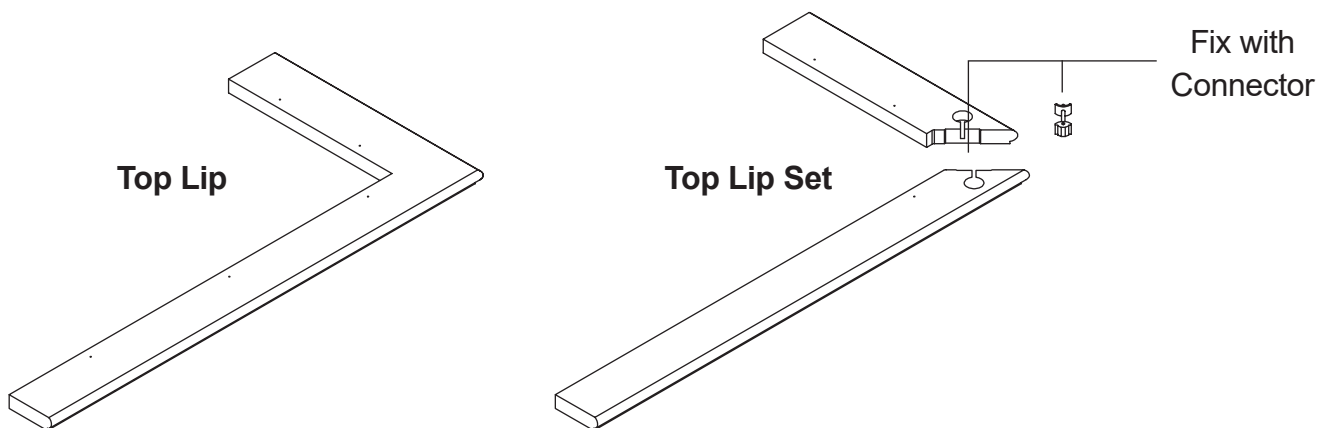

Locate the Top to the Box Tops using Dowels. It can be glued into place, screwed into place from beneath, or left as is. For 30mm Tops, use 45mm CSK Screws. For 18mm Tops, use 30mm CSK Screws. For exceptionally wide units, the Top and Skirting may be supplied in several lengths.

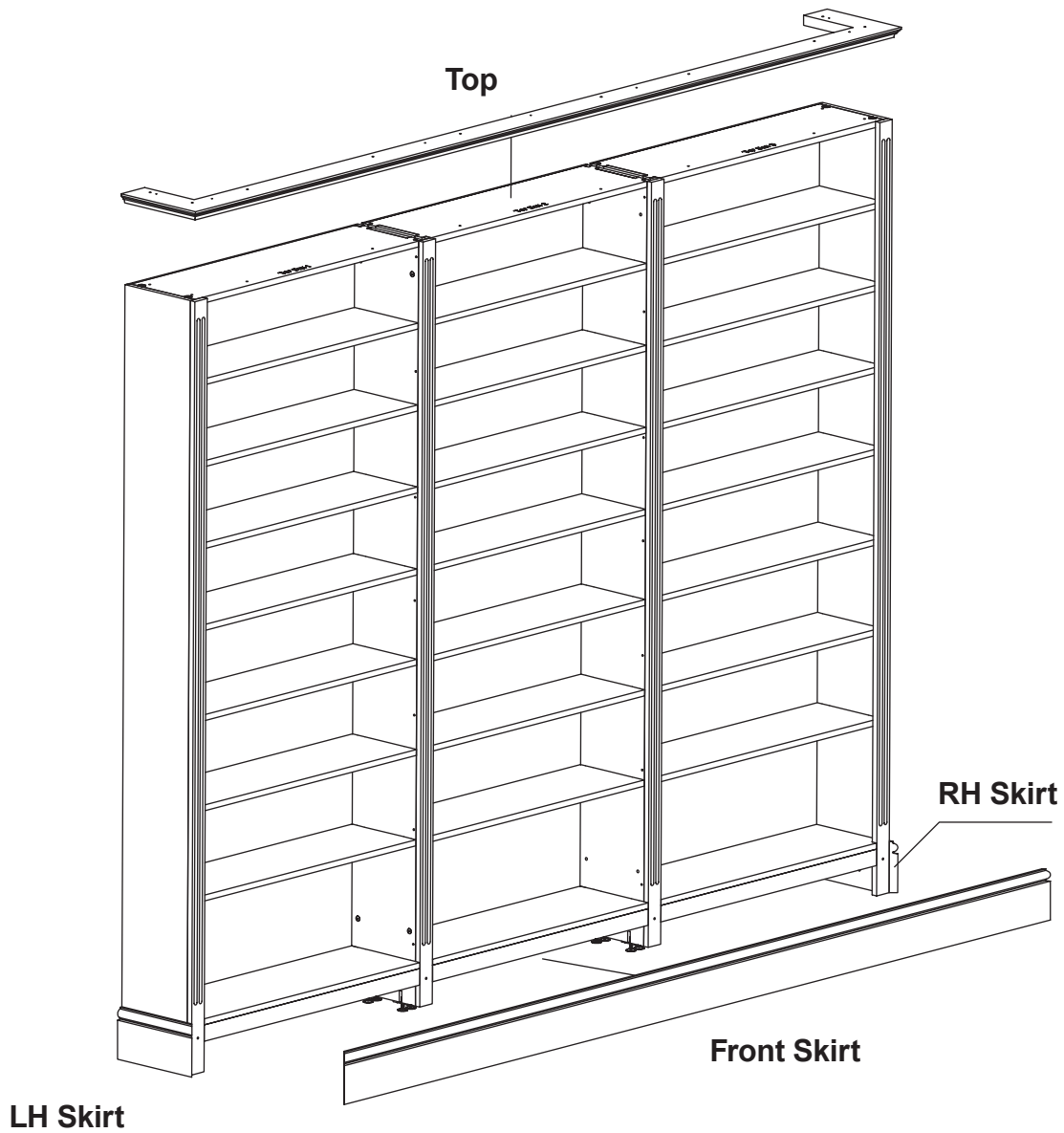

DOORS

15. Fix Handles to the Doors using the Bolts provided.

16. Where required, fix Doors in place with Hinges and 25mm CSK Screws. This will be easier with a helping hand! Ensure the butt of the hinge clears the edge of the door, so the doors are positioned correctly.

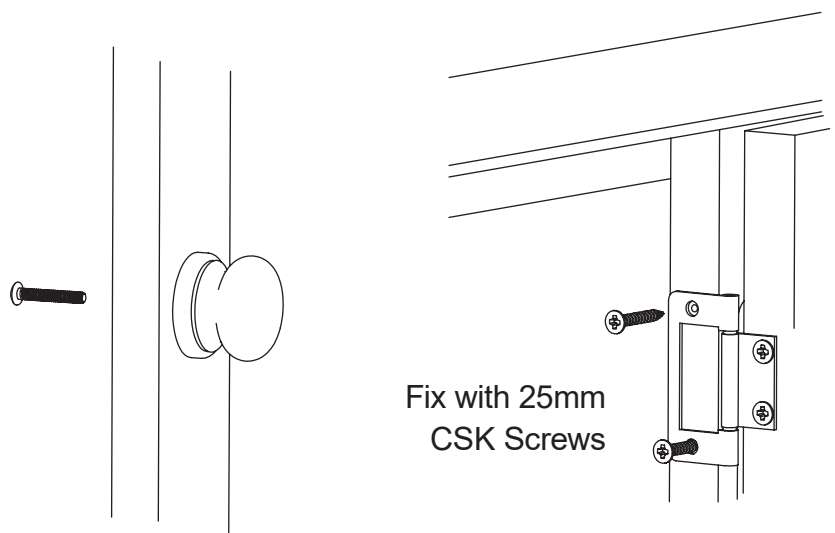

Fix with 16mm
PAN Screws

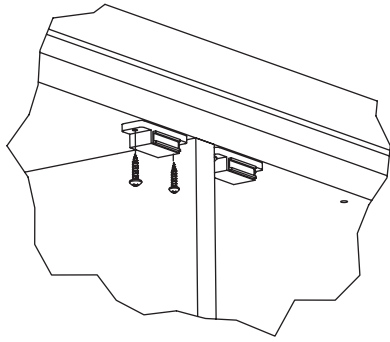

Fix with 16mm
CSK Screws

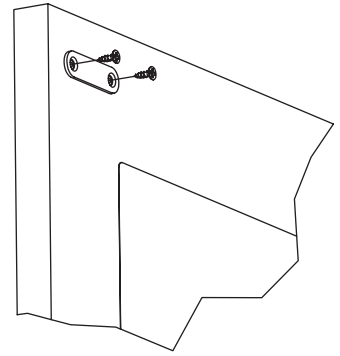

17. Fix Magnetic Catches to the required Box Tops with 16mm PAN Screws. The Catch should be towards the front, with the magnet facing outwards. Then, fix Magnetic Catch Plates to the back of any Doors with 16mm CSK Screws.

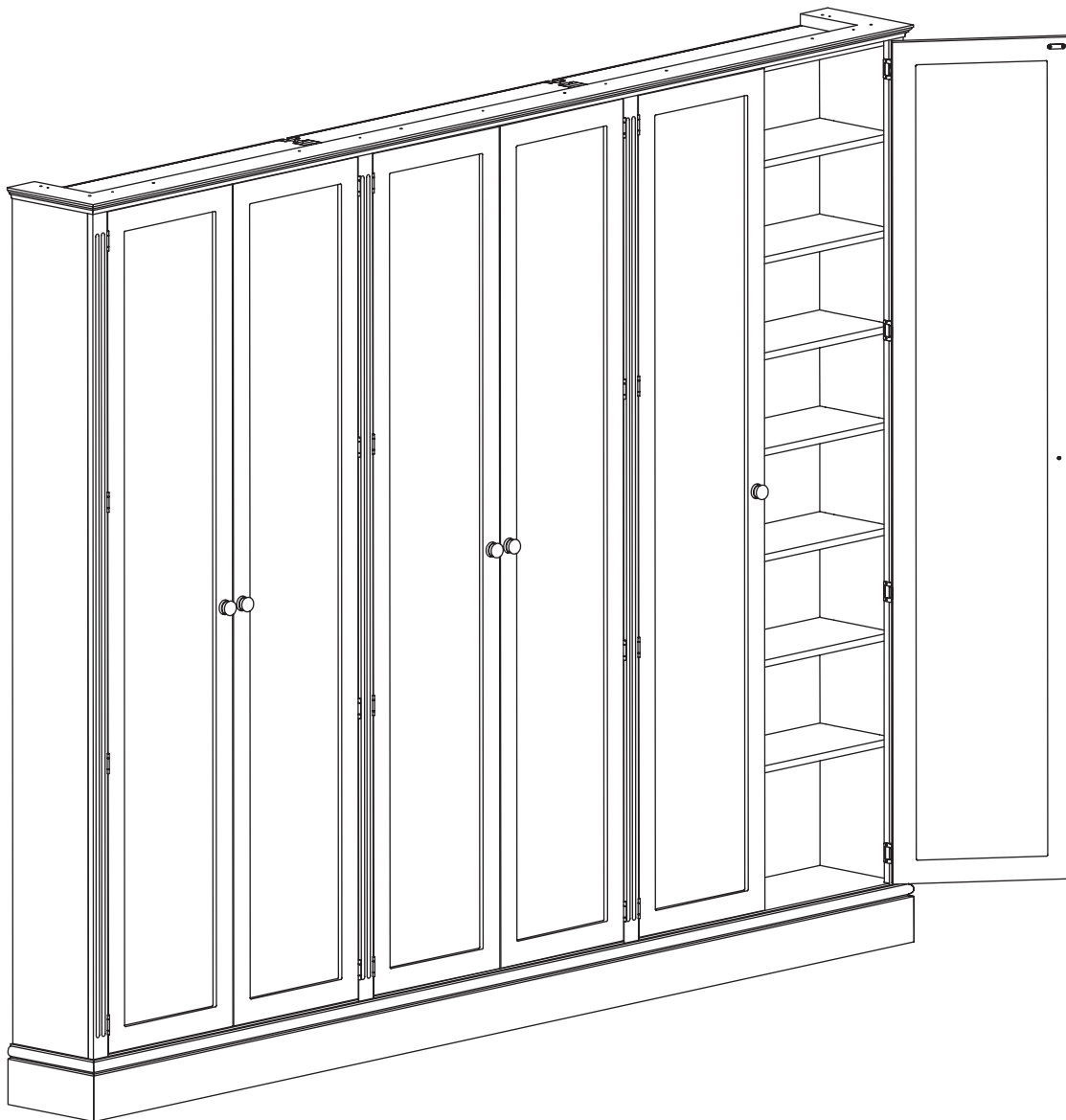

AND YOU'RE DONE!

#jali #cupboard #makeityours